

REVISIONS					
REV	ECO	DESCRIPTION	DATE	BY	APPR
A1	-	RELEASE NEW DWG FORMAT	12/JUN/15	ORION	-
A2	-	CORRECT SECTION DIMENSIONS	29/MAR/17	ORION	TOMMY
A3	C1070S	UPDATE DRAWING	28/JUN/19	JOE	TOMMY
A4	C1298S	UPDATE PLATING	14/SEP/20	SULLEN	TOMMY

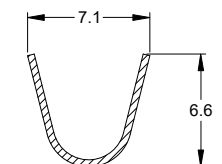
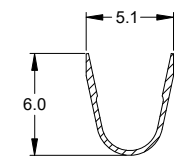
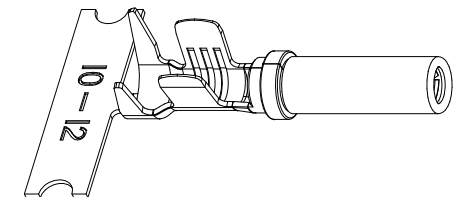
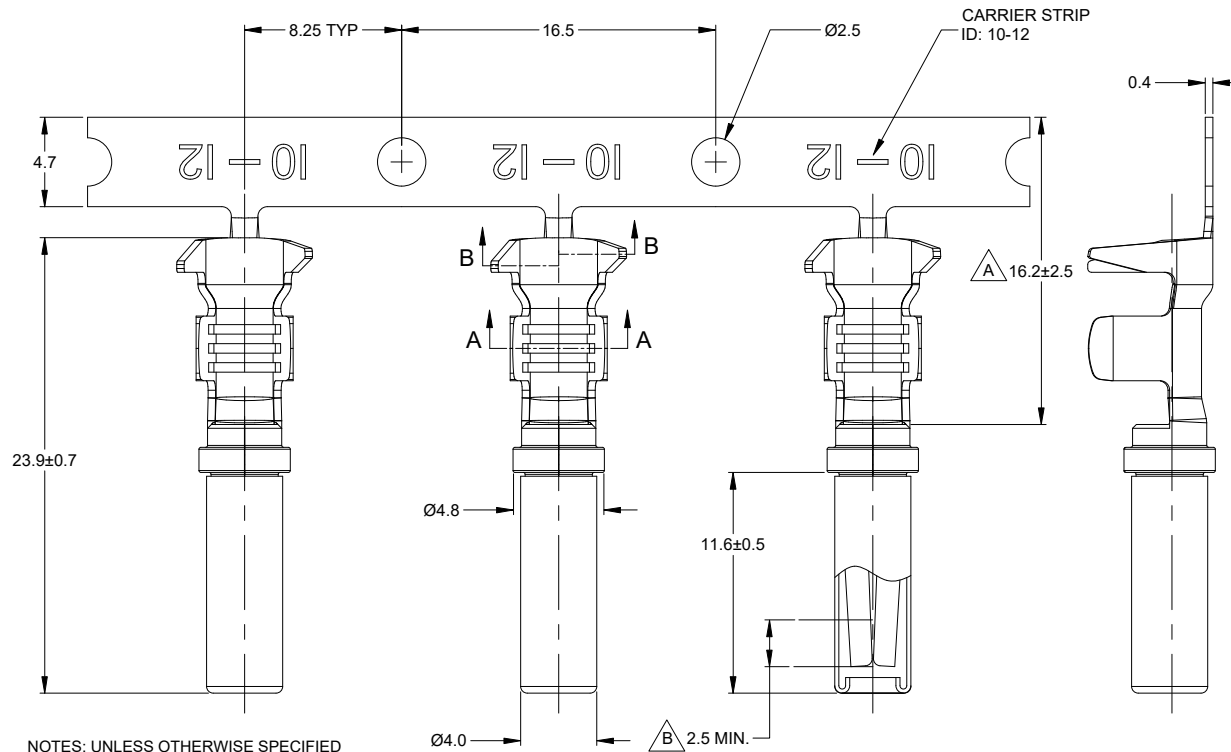

NOTES: UNLESS OTHERWISE SPECIFIED

1. MATERIAL: COPPER ALLOY
2. PLATING: SEE PART NUMBER CHART
3. CONTACT SIZE: 12
4. SPECIFICATIONS:
 - 4.1 CURRENT RATING: 25 AMPS
 - 4.2 CONTACT MILLIVOLT DROP: 100 MILLIVOLT DROP @ 25 AMP TEST CURRENT.
 - 4.3 RoHS COMPLIANT
5. RECOMMENDED WIRE RANGE: 10 - 12 AWG (6.0 - 4.0MM²)
RECOMMENDED INSUL O.D: 3.56 - 5.18MM (0.140 - 0.204INCH)
6. PACKAGE: 2000 PCS/REEL
7. AVAILABLE APPLICATORS: MFX-3973-K OR MFX-3973-G
8. ALL DIMENSIONS ARE FOR REFERENCE USE ONLY
9. ID MARK PRESENT OR NOT DETERMINES MANUFACTURER SITE

PART NUMBER CHART		
PLATING	PART NUMBER	PLATING DESCRIPTION
NICKEL	AT62-12-0222	SELECTIVE TIN OVER NICKEL OVERALL IN Δ ZONE
GOLD	AT62-12-0244	SELECTIVE GOLD FLASH OVER NICKEL OVERALL IN Δ ZONE OR ENTIRE CONTACT
TIN	AT62-12-0277	TIN OVER NICKEL OVERALL

SEE PART NUMBER CHART		REF: 1062-12-0222, 1062-12-0244															
PART NUMBER		DESCRIPTION															
QUANTITY		MATERIALS LIST															
UNLESS OTHERWISE SPECIFIED 1) All dimensions are in metric(mm) 2) Tolerances are as follows: 1 PL DEC ±0.30 Fractions ±1/64 2 PL DEC ±0.15 Angles ±1° 3 PL DEC ±0.08		<table border="1"> <thead> <tr> <th>SIGNATURES</th> <th>DATE</th> </tr> </thead> <tbody> <tr> <td>DRAWN: SULLEN,ZHANG</td> <td>14/SEP/20</td> </tr> <tr> <td>CHECKED: ORION,LI</td> <td>15/SEP/20</td> </tr> <tr> <td>ENGINEER:</td> <td></td> </tr> <tr> <td>APPROVAL: TOMMY,XIE</td> <td>16/SEP/20</td> </tr> </tbody> </table>		SIGNATURES	DATE	DRAWN: SULLEN,ZHANG	14/SEP/20	CHECKED: ORION,LI	15/SEP/20	ENGINEER:		APPROVAL: TOMMY,XIE	16/SEP/20				
SIGNATURES	DATE																
DRAWN: SULLEN,ZHANG	14/SEP/20																
CHECKED: ORION,LI	15/SEP/20																
ENGINEER:																	
APPROVAL: TOMMY,XIE	16/SEP/20																
MATERIAL SPECIFICATIONS:		<p>Amphenol</p> <p>Sine Systems - www.amphenol-sine.com 44724 Morley Drive Clinton Township, MI 48036</p>															
PROCESS SPECIFICATIONS:		<p>CONTACT, SOCKET, STAMPED, SIZE 12, 10-12 AWG, A SERIES</p>															
NEXT ASSY:		<table border="1"> <tr> <td>SIZE</td> <td>TYPE</td> <td>DWG NO:</td> <td>REVISION</td> </tr> <tr> <td>B</td> <td>C-</td> <td>AT62-12-02XX</td> <td>A4</td> </tr> </table>	SIZE	TYPE	DWG NO:	REVISION	B	C-	AT62-12-02XX	A4	<table border="1"> <tr> <td>SCALE</td> <td>NONE</td> <td>SHEET</td> <td>1</td> <td>OF</td> <td>1</td> </tr> </table>	SCALE	NONE	SHEET	1	OF	1
SIZE	TYPE	DWG NO:	REVISION														
B	C-	AT62-12-02XX	A4														
SCALE	NONE	SHEET	1	OF	1												

TITLE: CONTACT STAMPED SIZE 12, 10-12 AWG, A SERIES
DWG NO.: AT62-12-02XX
REV: A4
SH: 1
OF: 1